

BASE RACK FITTING INSTRUCTION

Part Number(s):
17940080

Suits BASE RACK:
1770060/70

Product Description: **BASE RACK fitting kit suits:**
• **2022 on Ford Ranger dual cab (all models)**

WARNING

REGARDING VEHICLES EQUIPPED WITH SRS AIRBAG:

When installed in accordance with these instructions, the cab rack does not affect operation of the SRS curtain airbags.

ALSO, NOTE THE FOLLOWING:

- ◆ This product must be installed exactly as per these instructions using only the hardware supplied.
- ◆ In the event of damage to any cab rack component, contact your nearest authorised ARB stockist. Repairs or modifications must not be attempted.
- ◆ Do not use this product for any vehicle make or model, other than those specified by ARB.
- ◆ Do not remove labels.
- ◆ This product or its fixing must not be modified in any way.
- ◆ The installation of this product may require the use of specialized tools and/or techniques.
- ◆ It is recommended that this product is only installed by trained personnel.
- ◆ These instructions are correct as at the publication date. ARB Corporation Ltd. cannot be held responsible for the impact of any changes subsequently made by the vehicle manufacturer.
- ◆ During installation, it is the duty of the installer to check correct operation/clearances of all components.
- ◆ Work safely at all times.
- ◆ Unless otherwise instructed, tighten fasteners to specified torque.

ARB 4x4 ACCESSORIES

Corporate Head Office

42-44 Garden St
Kilsyth, Victoria
AUSTRALIA 3137

Tel: +61 (3) 9761 6622
Fax: +61 (3) 9761 6807



Australian enquiries
North & South American enquiries
Other international enquiries

sales@arb.com.au
sales@arb.com.au
exports@arb.com.au

www.arb.com.au



FITTING REQUIREMENTS

REQUIRED TOOLS FOR FITMENT OF PRODUCT:

Basic tool kit	Centre punch & small hammer
Torque wrench	Metric Torx key set
7.0mm drill bit	Metric Allen key set
<p style="text-align: center;">Step drill bit to suit a <u>10.0mm</u> hole</p> <p style="text-align: center;">A conventional drill bit cannot be used or rivnuts will not seal correctly.</p> <p style="text-align: center;"><u>IMPORTANT:</u></p> <p style="text-align: center;">Step drill bit from the 10mm step <u>must not</u> exceed 30mm in length or you risk drilling into the curtain air bags. (Drill bit shown is only 20mm in length).</p>	<p style="text-align: center;">Rivnut gun (similar to the one pictured below)</p> <div style="text-align: center;">  </div>
	

SAFETY

HAVE AVAILABLE THESE SAFETY ITEMS WHEN FITTING PRODUCT:

Protective eyewear 	Hearing protection 
--	--

NOTE: 'WARNING' notes in the fitting procedure relate to OHS situations, where to avoid a potentially hazardous situation it is suggested that protective safety gear be worn or a safe work procedure be employed. If these notes and warnings are not heeded, injury may result.

FASTENER TORQUE SETTINGS:

SIZE	Torque Nm	Torque lbft
M6	9Nm	7lbft
M8	22Nm	16lbft
M10	44Nm	32lbft
M10 Seat Belt Bolts	48Nm	35lbft
M12	77Nm	57lbft

NET PAYLOAD FOR YOUR BASE RACK

The net payload for your BASE RACK is calculated by subtracting the weight of the BASE RACK and the vehicle mounting kit from the vehicle's roof capacity. The table below gives the BASE RACK net payload for fitting kit 17940050, using the vehicles maximum vehicle roof capacity. The vehicle's roof load capacity may vary between models and driving conditions. Refer to vehicle owner's manual for model and condition specific roof load capacities.

Kit	BASE RACK	Vehicle roof capacity* (kg/lb)	BASE RACK + mount kit (kg/lb)	BASE RACK net payload (kg/lb)
17940080	1770060/70	ALL MODELS (EXCEPT RAPTOR) 85 / 187	20 / 44	65 / 143
		RAPTOR 80 / 176	20 / 44	60 / 132

* Maximum roof load capacity. Refer to vehicle owner's manual for model and condition specific roof load capacities.

It is important to follow these safety instructions;

- ◆ Maximum load per BASE RACK beam is 25kg.
- ◆ Load must be evenly distributed and adequately secured.
- ◆ Any weight carried on the roof of the vehicle will adversely affect its handling, particularly in cornering or in a cross-wind, the vehicle should therefore be driven with increased discretion.
- ◆ Regularly check the tightness of the securing clamps and the security of the load.
- ◆ Attention is directed to statutory requirements regarding maximum permissible projections from vehicles.

All bolts should be checked prior to touring to ensure the tray is fastened correctly

GENERAL CARE AND MAINTENANCE

By choosing an ARB BASE RACK, you have bought a product that is one of the most sought after 4WD products in the world. Your BASE RACK is a properly engineered, reliable, quality accessory that represents excellent value. To keep your BASE RACK in original condition it is important to care and maintain it following these recommendations:





- As part of any pre-trip preparation, or on an annual basis, it is recommended that a thorough visual inspection of the BASE RACK is carried out, making sure that all bolts and other components are torqued to the correct specification. Replace any components as necessary.

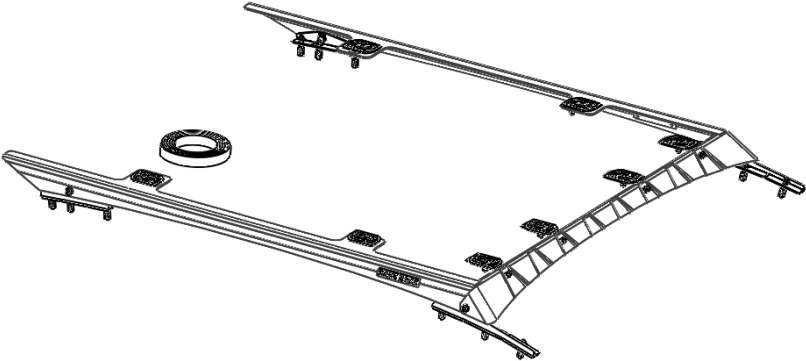



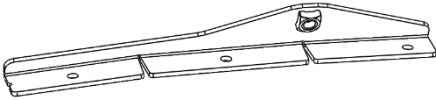
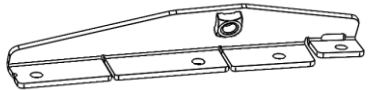
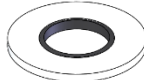
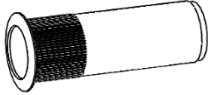
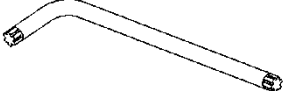

Please contact local Authorised ARB Stockist if you would like to have this service carried out on your behalf.

PARTS LISTING - BASE RACK fitting kit

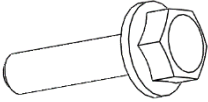
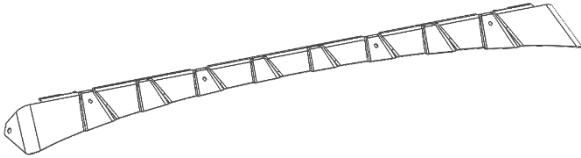
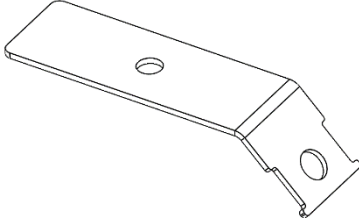
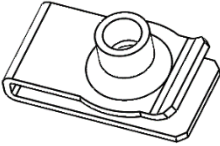
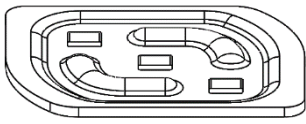
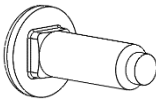
PART NUMBER	SUITS BASE RACK	QTY	DIAGRAM
17940080	1770060/70	1	

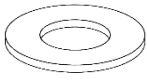
PARTS LISTING 17940080

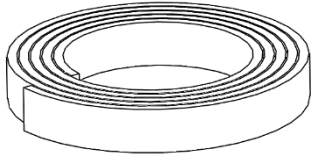
PART NO.	PICTURE	QTY	DESCRIPTION
3750573L		1	BLADE BRACKET RANGER LH
3750573R		1	BLADE BRACKET RANGER RH
4655165 L&R		1 PR	FRONT MOUNTING FOOT L&R
4655166 L&R		1 PR	REAR MOUNTING FOOT L&R
4584415		12	M8 WASHER FLAT - BONDED
6151996		12	NUTSERT M6x1.0
6151934		1	TORX ALLEN KEY
6151625		4	M8 X 1.25 X 25 BUTTON HEAD TORX - BLK
4581085		16	M8 WASHER FLAT - BLACK

6152008		12	FLANGE HEAD BOLT M6x25
3750574		1	FRONT DIFFUSER
3750575		4	DIFFUSER MOUNT BRACKET
6151475		4	M6 U-NUT
3195184		8	M8 STUD PLATE
6151921		12	M8 X 20 STUD - BLACK
6151212		12	M8 X 1.25 NYLOC NUT - BLACK
4584329		6	M6 WASHER FLAT - BLACK
6151459		6	M6 BTN HEAD SCREW – BLACK
668PB028		1	24mm FOAM TAPE ROLL
6781408		1	DOUBLE SIDED TAPE

FITTING PROCEDURE



The interior roof lining needs to be dropped to install the cab rack kit.

Note: Ensure you retain all fasteners and clips to use when reinstalling the roof lining.

1. Pull back the door seal on the top half of the rear door jamb. Unclip and pull back the side rear pillar trims on both sides.



2. Remove the front and rear roof grab handles. This is done by removing plastic covers to expose the torx head screws.

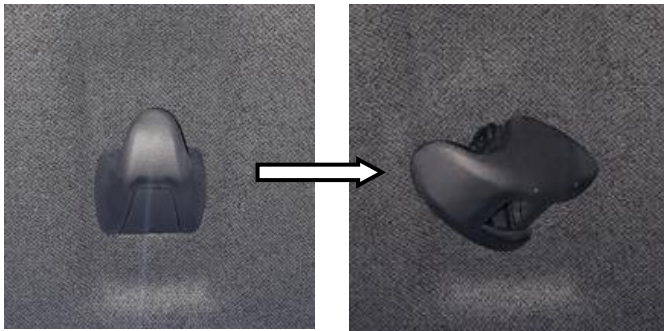

3. Remove the centre cap of the rear window hooks and rotate 45deg.
Pull the hooks out.



4. On the B-pillar, remove the plastic cap to expose the retaining bolt on both front seat belts.

Undo the Torx head bolt on each front seat belts and remove.

Allow the seatbelt to hang down as shown.





5. Remove the plastic caps on the B-pillar grab handles to expose the torx screws.

Remove torx screws to remove the handles.



6. Unclip and remove the B-pillar plastic trim on both sides.

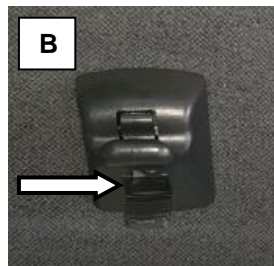
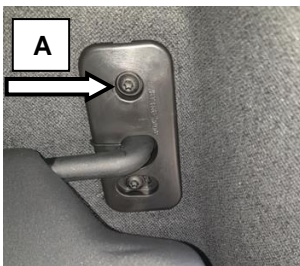

7. Remove the front sun visors (A) by using a small flat blade screwdriver to unclip the plastic cover exposing the hex head screw.

Remove the visor retaining clips (B) by removing the torx head screws.

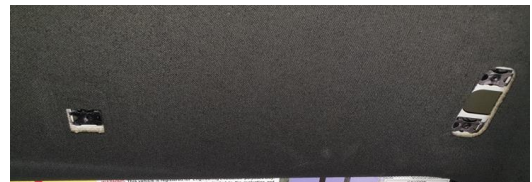

8. Remove the grab handle on the RHS A-pillar trim. There are two small hex bolts behind the plastic caps.

FITTING PROCEDURE



9. Unclip the A-pillar plastic trim.



10. Unclip the overhead console.
Disconnect the 2x electrical plugs running to the unit.
Unclip the plastic trim above the rear vision mirror



11. Remove the 2x torx screws.



12. The roof lining can now be dropped down.
The roof lining wiring harness is glued to the roof lining so just let it hang as shown.



13. Remove the aluminum gutter trims from the roof. There is a large nut on the ends of each trim on the inside of the roof skin.



14. Remove the rear pieces on each roof gutter trim.

These end pieces will be reused during the installation of the roof rack kit.

Discard all other items.

Note: If vehicle has rubber trims, skip to step 16.



15. Drill out the threaded holes on the end trims to 7.0mm as shown.



Warning: The following steps must be followed with care not to cause any damage to the curtain air bag system on the vehicle.



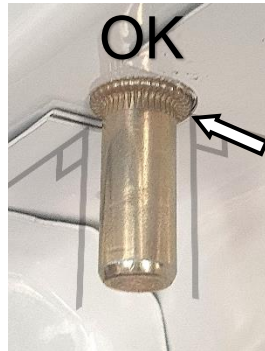

16. Using a rivnut gun, fit rivnuts to the front and rear holes on both roof gutters as shown. Rear holes need the rivnut installed in the centre of the slot.

Note: Ensure the rivnuts are done up tight. If they are not installed correctly, they may leak.



When installing the rivnuts, make sure:

 - Rivnut is perpendicular to the sheet metal.

 - Rivnut is fully compressed (refer image).

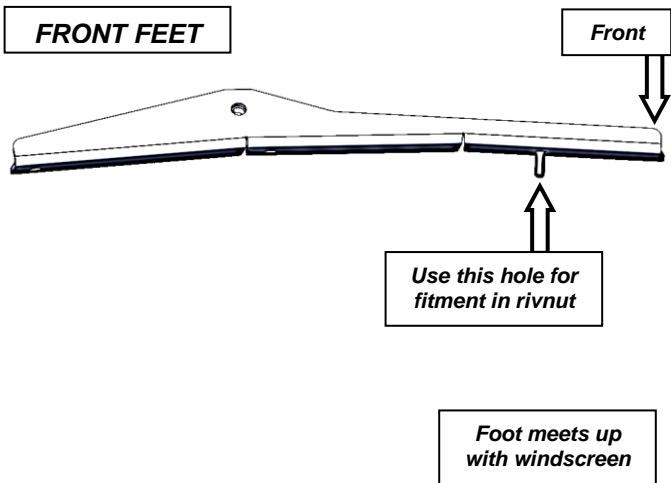

17. Mount the 2x front feet to the front rivnuts fitted in step 16 using 1x M6 flange bolt per

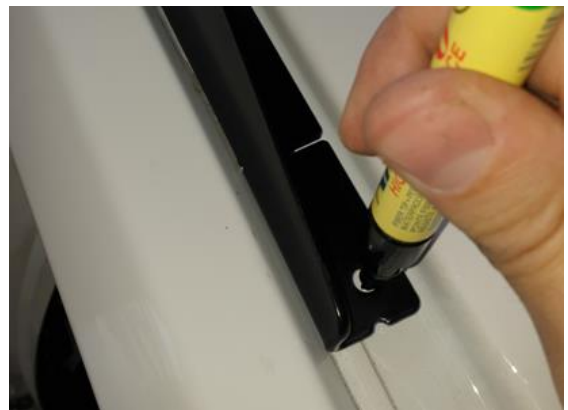

foot as shown in the top image.

The front of the foot meets up with the windscreen as shown.

Centralize the feet and mark the hole centres of the other 2x holes per foot.

Remove the feet and use a centre punch on the marks.

REAR FEET

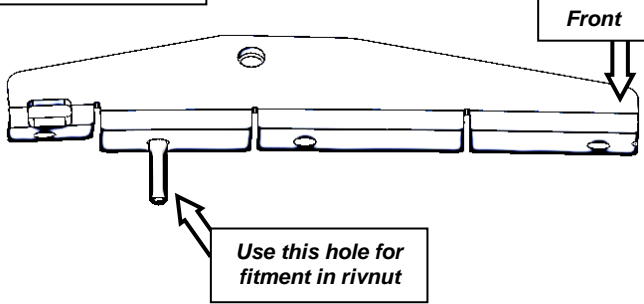

18. Mount the 2x rear feet to the rear rivnuts fitted in step 16 using 1x M6 flange bolt per foot as shown in the top image.

Note: The front of the foot has a small notch as shown.

Centralize the feet and mark the hole centres of the other 2x holes per foot.

Remove the feet and use a centre punch on the marks.



19. Use low tack film or similar to protect the areas around holes that need drilling as shown.



20. Unclip the airbag wiring harness from the vehicle roof on both sides (shown in left image).

The below image shows the position of the clips on the rear of the vehicle roof.

Warning: This wiring loom must be moved out of the way before drilling the holes.



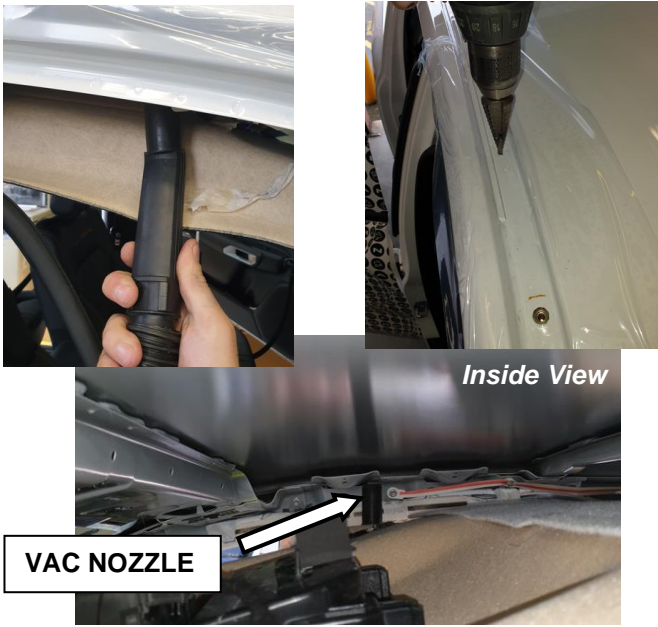

21. Drill the 8x mounting holes in the gutters out to $\varnothing 10.0\text{mm}$ using a step drill.

***See drill specs on page 2**

NOTE: Use a shop-vac directly underneath the hole being drilled to ensure no metal debris gets caught on the air bags or roof lining.

Hint: Use the nozzle of the shop-vac to pull the air bags and wiring away from the area being drilled as shown in the "Inside View" image.



22. Using a rivnut gun, fit rivnuts to the 8x holes. There should now be 12x rivnuts installed in the roof.

Note: Ensure the rivnuts are done up tight. If they are not installed correctly, they may leak.

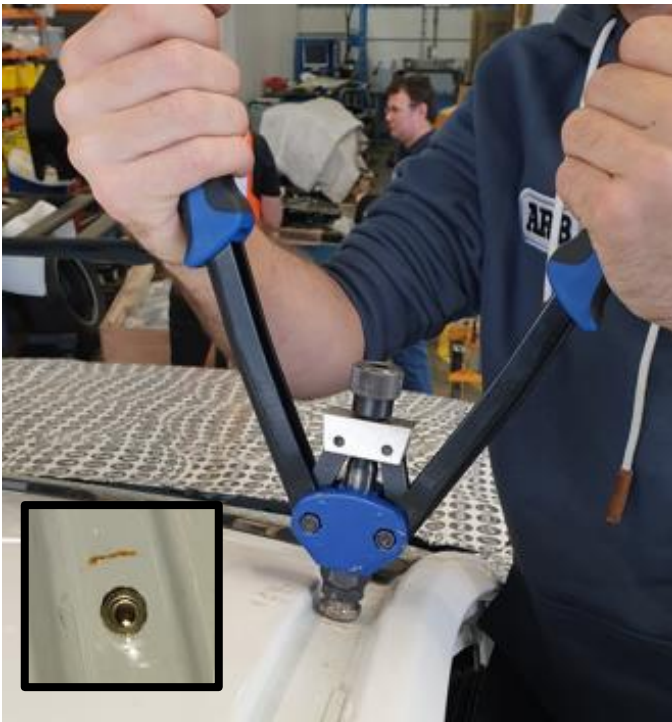

23. Measure and cut 4x pieces of foam seal to fit on the underside of the mount feet.





24. Fit the foam seal on the feet. Using a 7.0mm drill bit, drill through the mount feet holes to open up the foam seal.



M6x25 flange head bolt
bonded washer

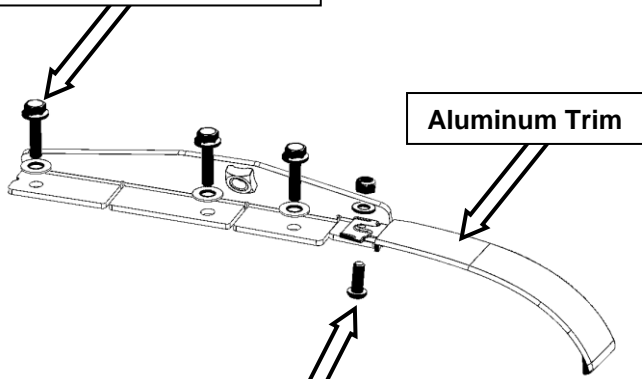

M6 button head screw
M6 washer
M6 nyloc nut

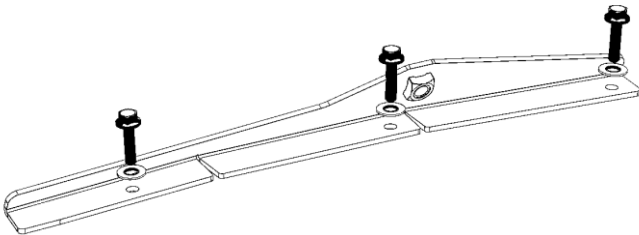

25. Attach the aluminum trims to the rear feet (prepared in step 15) using 1x M6 button head screw, washer and nyloc nut.

Bolt the front and rear mount feet to the roof using M6 flange head bolts & rubber bonded washers as shown.

Tighten all 12x M6 bolts to specified torque.



 M6 - 9 Nm.

Note: For vehicles with a rubber trim:

The rear of the trim will need to be cut to fit and attached with double sided tape as shown below:



If fitting 1780400 or 1780410 wiring kit, fit now. Refer to page 19 of the instructions for location.

26. The interior of the vehicle can now be reassembled by completing steps 1-12 in reverse order.

The torque spec for the seat belt bolts removed in step 4 is:

 M10 Seat Belt Bolts - 48 Nm.

Note: Ensure there is no metal debris left on or around the curtain airbags. Use the shop vac to carefully clean away any debris left from the drilling process.

Generic Image

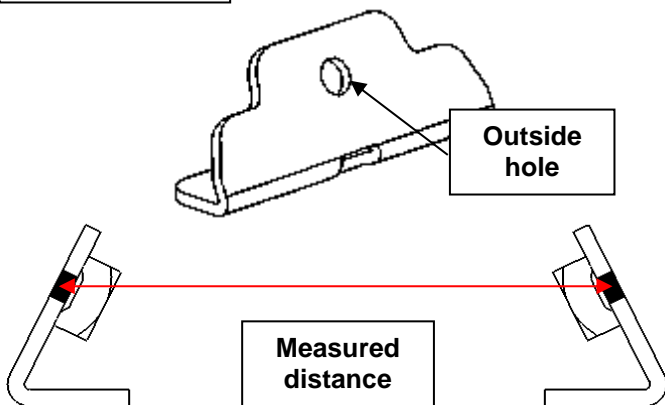

27. Using a tape measure, measure across the vehicle between the middle of the hole on the outside face of the front and rear set of mounting brackets. Make a note of each measurement.

Position	Distance
Front	
Rear	

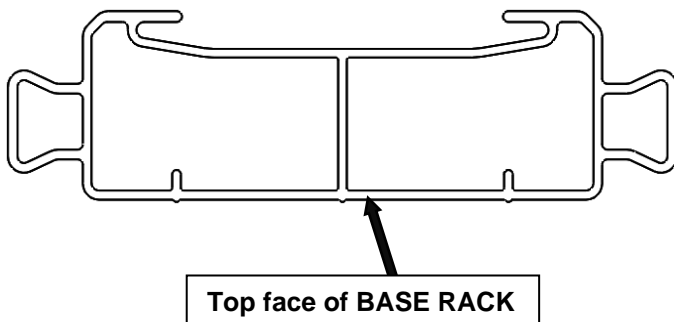

28. Place the BASE RACK face down on a clean flat surface. Provide protection to the top face of BASE RACK to avoid marking of surfaces

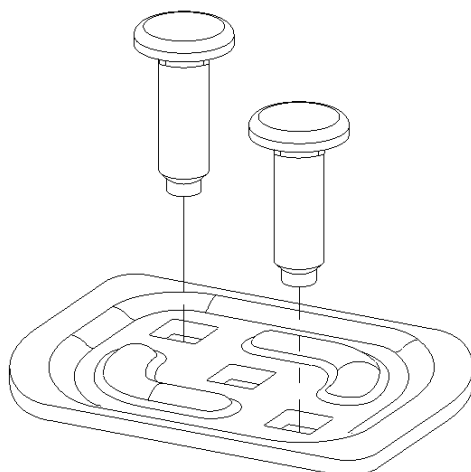

29. Insert 2, M8 x 25 Studs into 4 of the Stud Plates as shown.

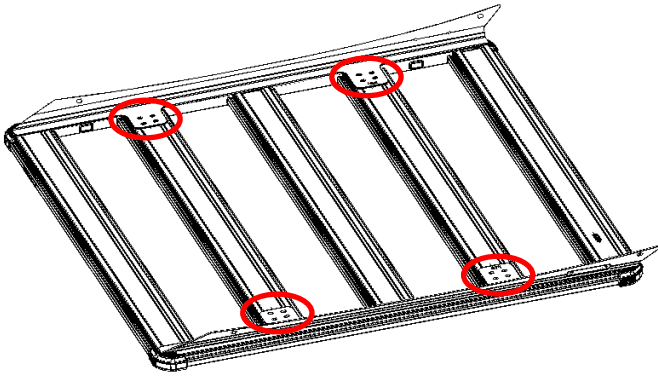

30. Check the position of the mounting plates (circled in image) on the blade brackets in relation to the channels on the BASE RACK.

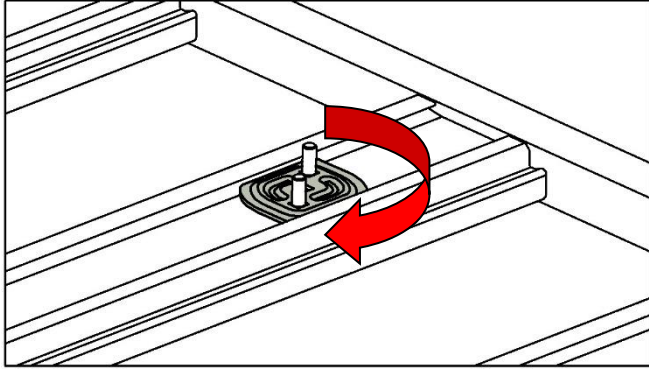

31. Insert the previously assembled stud plates into the correct BASE RACK channels. Rotate the plates 90 degrees.

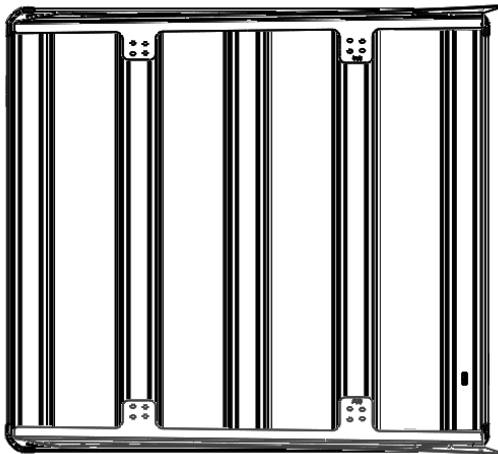
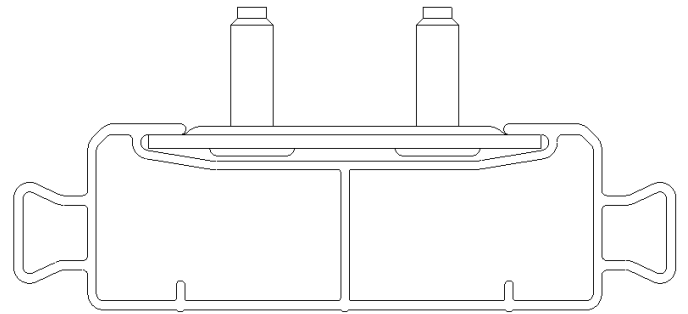

32. Flip the blade brackets over so they are upside down and carefully place on top of the BASE RACK. When doing so ensure the M8 studs in the stud plates go through the slots. Then secure the blade brackets to the BASE RACK using M8 flat washers and nyloc nuts.

Do not fully tighten, allowing each blade to move.

Generic Image

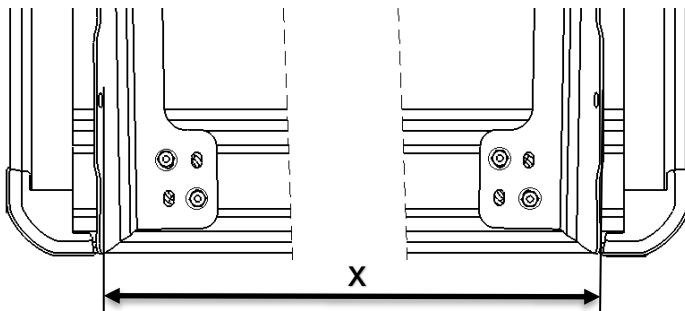
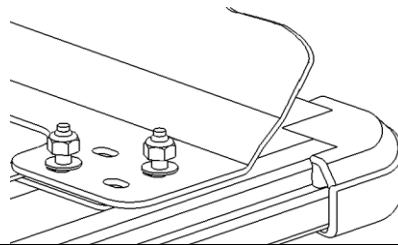

Generic Image

33. Using the previously recorded measurements, adjust the location of the blade bracket on the BASE RACK.

Ensure the distance between the blade bracket and the edge of the tray is the same on both sides. Fully tighten all M8 nyloc nuts to specified torque.

 **M8 - 22Nm**

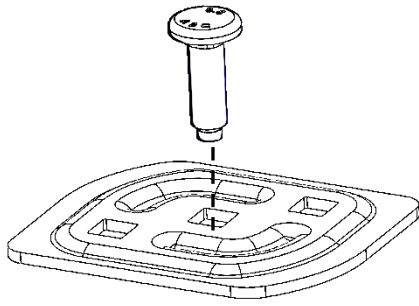

34. Insert an M8 x 25 Stud into 4 of the Stud Plates as shown.

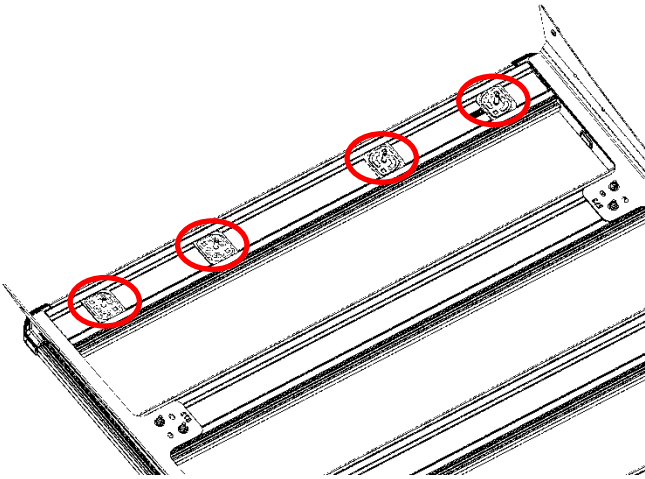

35. Insert the previously assembled stud plates into the front BASE RACK channel. Rotate the plates 90 degrees.

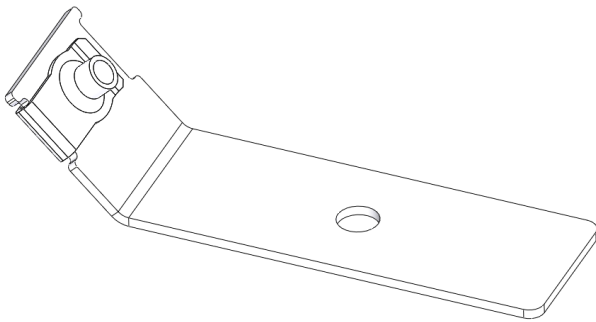
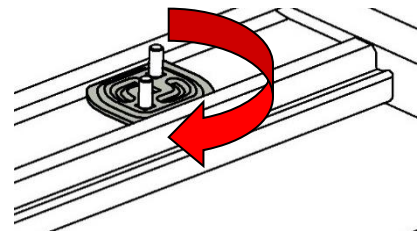

36. Fit M6 U-nuts to the 4x diffuser brackets as shown. The thread needs to be on the inside.

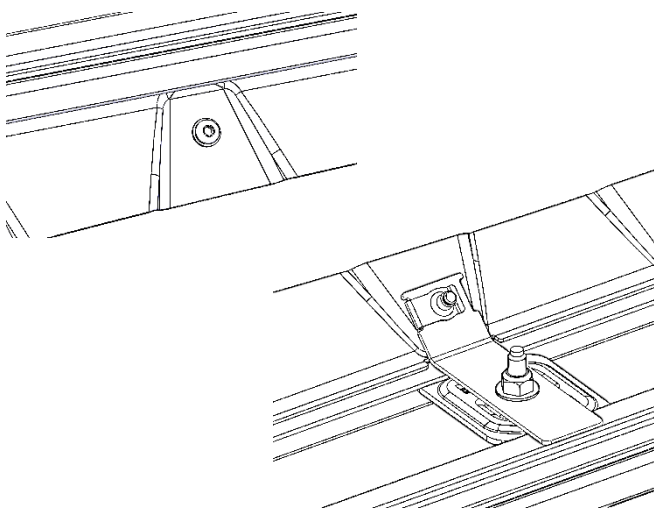

37. Loosely fit the diffuser to the mounts and brackets as shown. Use an M8 nyloc nut and washer to hold the diffuser brackets to the stud plates. Use M6 screws and washers to hold the diffuser to the brackets.

38. Tighten to specified torque.

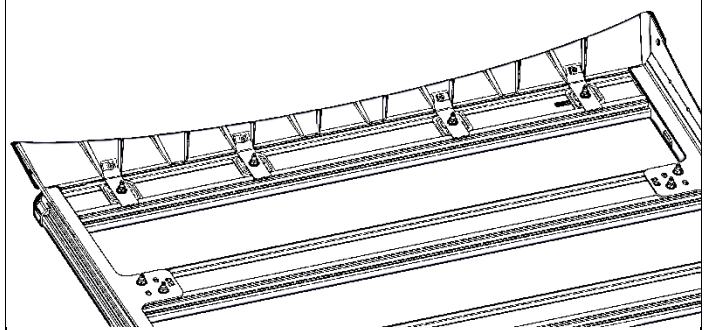

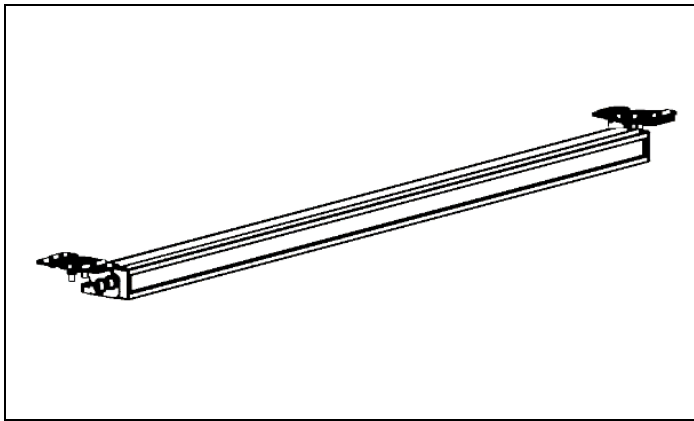

39. If fitting a BASE RACK lightbar it should be fitted to the BASE RACK at this point. Refer to instructions provided with the BASE RACK light bar for fitting details.

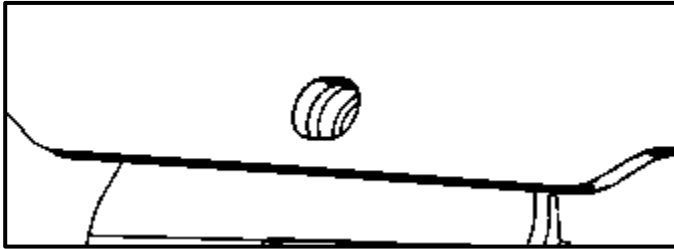

40. With assistance, carefully place the BASERACK on the vehicle so the inside of the blade brackets rests on the outside of the mounting brackets. The entire BASERACK assembly should be clear of the vehicle roof. All mounting holes/slots should align closely.

41. Note: Place protective material on roof to reduce the risk of accidental damage to vehicle when mounting the BASERACK to the vehicle.

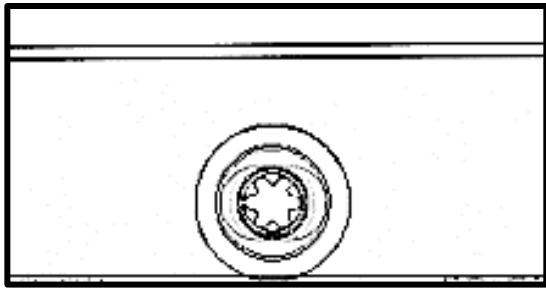

42. Confirm BASE RACK is correctly aligned to vehicle. If it is not it is recommended to remove the BASE RACK from the vehicle roof and repeat the mounting process from the measurement step 27.

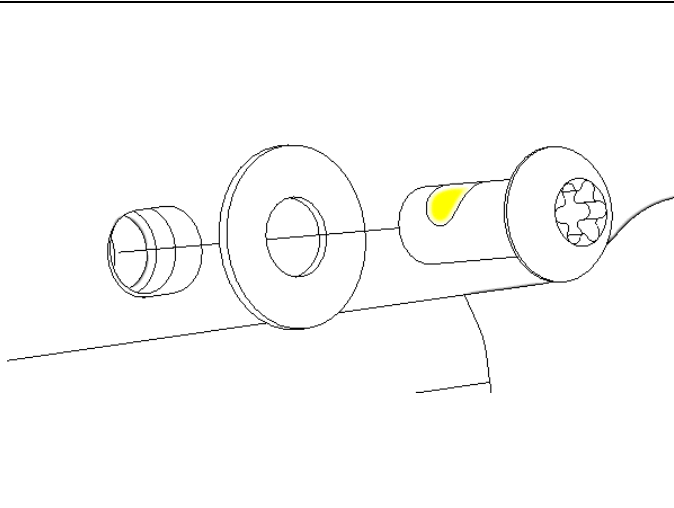

43. Use the M8 Button head Torx screws and M8 Black washers to secure the roof tray to the roof mounting brackets. Tighten all screw to the specified torque.



FITTED PRODUCT – 2022 Ford Ranger with 1770070 Base Rack



OPTIONAL STEP FOR BASE RACK WIRING KIT

(1780400 & 1780410 SOLD SEPARATELY)

These steps are a vehicle specific supplement to the main instruction, this instruction should be used in parallel. Read both instructions before proceeding.

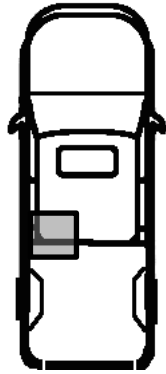

1. The recommended location for the wiring kit for this vehicle is the rear, left hand side.
2. The location provided has been chosen to provide a safe passage away from vehicle components (airbags, vents, etc) and integrated to the rack.

! CAUTION – THIS STEP MAY REQUIRE DISASSEMBLY OF SEAT BELT MOUNTS AND WORK IN THE PROXIMITY OF CURTAIN AIR BAGS!

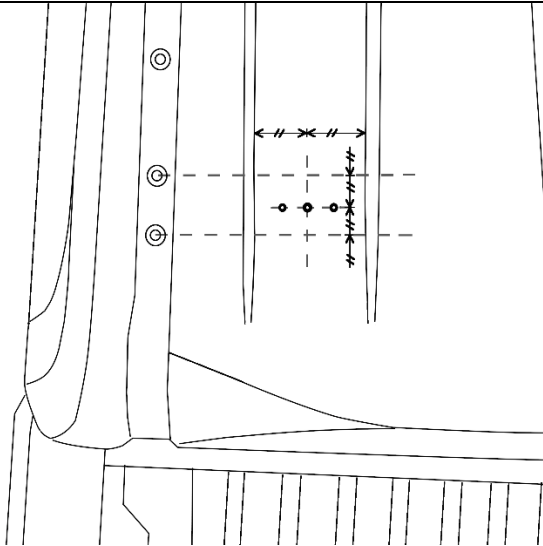

3. Use the hole locations shown. Always verify they are clear inside the cabin before drilling.

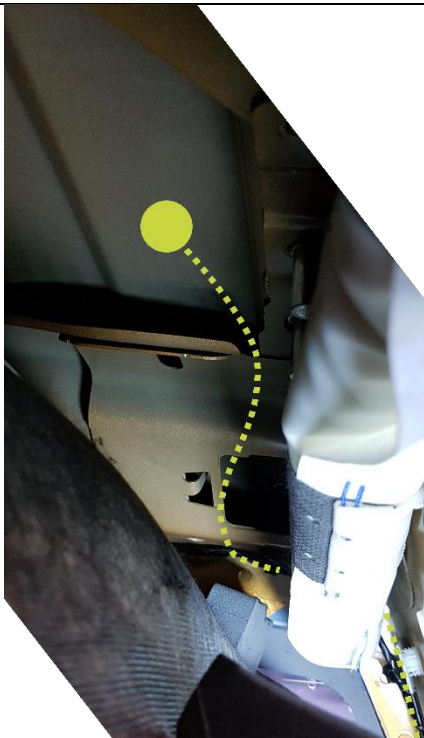

4. Run the wiring backward then follow and secure to the existing wiring loom down the rear pillar.

ENSURE THE WIRING IS BEHIND THE AIRBAG.

Obstruction of the airbag will prevent proper inflation and effectiveness.